

proportional directional valve type USAB6

NS 6 | p_{max} 31,5 MPa | Q_{max} 60 dm³/min | WK 420 740



DATA SHEET – OPERATION MANUAL

DEVICE CHARACTERISTICS

Proportional directional valve type USAB6... is used to control the direction and speed of movement of a receiver. Flow rate of hydraulic oil directed to the receiver is adjusted by change of electric current supplying the solenoid coil.

OPERATION DESCRIPTION

The main elements of the proportional directional valve type USAB6... are: the valve body 1, proportional solenoids 2 and 4, the spool 3 and springs 5 and 6. Solenoids 2, 4 move the spool 3 from the neutral position, proportionally to the supplied current. It makes it possible to control both the direction and the flow rate of oil in the system, which allows for changing the direction and speed of the receiver motion. Return of the spool 3 to the neutral (de-energized) position is provided by the centering springs 5 and 6. The shape of the spool (control edge spacing) affects the configuration of connections between the ports: P, A, B, T as shown on the hydraulic diagrams, and different shapes and flow cross-sections influence the nominal performance of the directional valve and the nature of flow change (linear or progressive). A list of electronic controllers that can be used for controlling the proportional solenoids 2 and 4 is shown in the table on page 2. Solenoids 2 and 4 can be equipped with manual override buttons 7 allowing for manual override of the directional valve in the event of power failure.

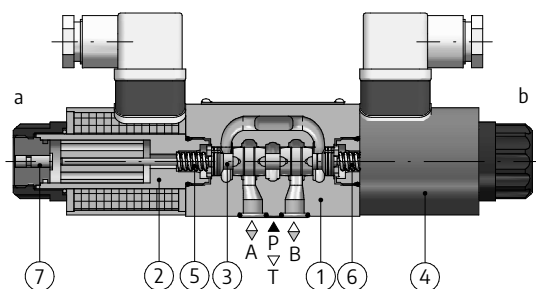

TECHNICAL PARAMETERS

hydraulic fluid	mineral oil	
required fluid cleanliness class	ISO 4406 class 20/18/15	
nominal fluid viscosity	37 mm ² /s at temperature 55 °C	
viscosity range	2,8 ÷ 380 mm ² /s	
fluid temperature range (in a tank)	recommended 40 ÷ 55 °C	
	maximum -20 ÷ +70 °C	
ambient temperature range	-20 ÷ +50 °C	
maximum operating pressure	ports: P, A, B – 31,5 MPa	
	port T – 25 MPa	
hysteresis	< 6% Q_{max}	
repetition accuracy	< 3% Q_{max}	
operating position	optional	
weight	with 1 solenoid – 1,5 kg	
	with 2 solenoids – 2,1 kg	
maximum current of solenoid coil	1,5 A	0,8 A
resistance of cold solenoid coil (20°C)	5,4 Ω	19,5 Ω
electronic amplifiers	according to table on page 2	
installation and operation requirements	available on:	
http://eksploatacja.ponar.pl/general_operating_conditions_EN_03.2019_01.pdf		

HYDRAULIC DIAGRAMS

3-position directional valves

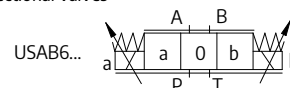

spool diagrams

working and indirect positions

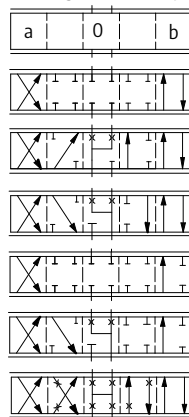

working positions

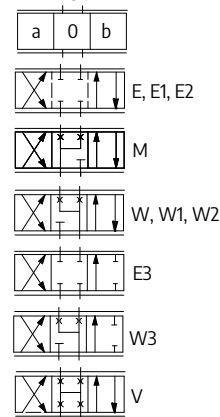

2-position directional valves

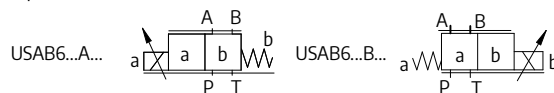

spool diagrams

working and indirect positions

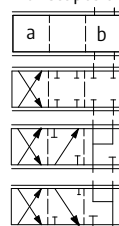

working positions

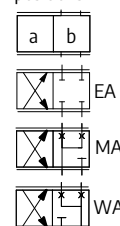

working and indirect positions

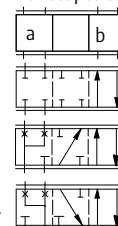

working positions

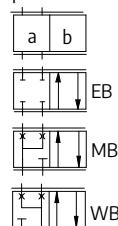

ELECTRONIC AMPLIFIERS

max current of solenoid coil	1,5 A	0,8 A
	30RE20 to Data Sheet WK 495 773	–
	30RE20D to Data Sheet WK 420 830	–
electronic amplifier	30RC20D* to Data Sheet WK 430 340	
	MAP2* to Data Sheet "electronic joystick" on website www.ponar-wadowice.pl	
	(*) – when powered by a stabilized voltage 24 V DC set the maximum current value I_{max}	

FLOW RATE VALUES

spool symbol	flow rate			
	P → A	P → B	A → T	B → T
E1, W1	Q_{max}	$Q/2$	Q_{max}	$Q/2$
E2, W2	$Q/2$	Q_{max}	$Q/2$	Q_{max}
E3, W3	Q_{max}	Q_{max}	Q_{max}	closed

PERFORMANCE CURVES

measured at viscosity $\nu = 41 \text{ mm}^2/\text{s}$ and temperature $t = 50 \text{ }^\circ\text{C}$

flow rate curves related to the reference signal I at constant Δp ranges

spool type EL10

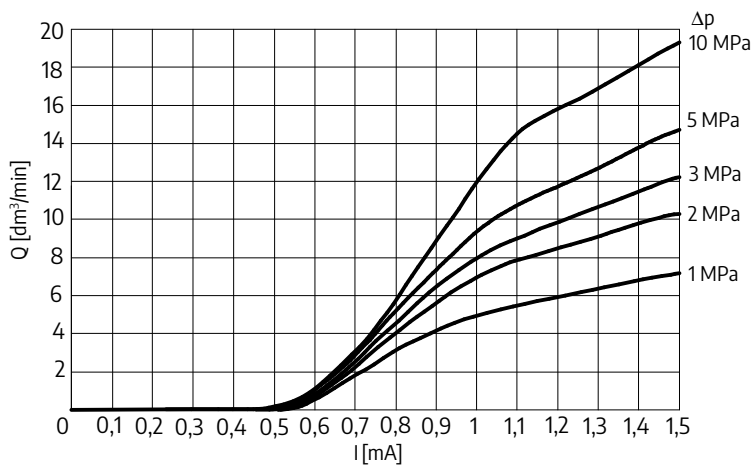

spool type EQ10

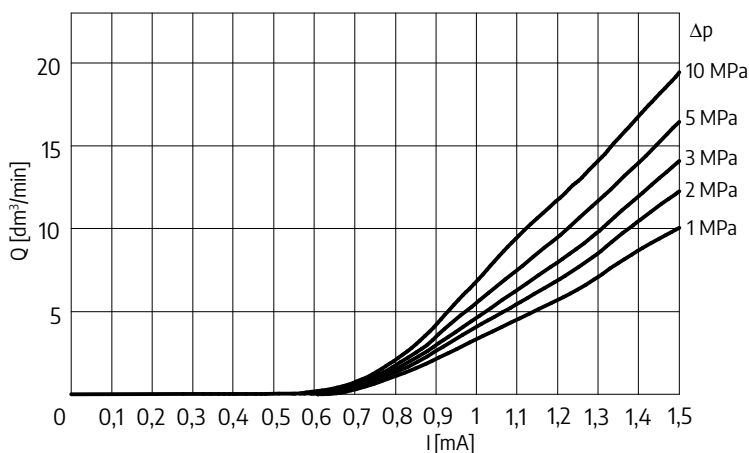

flow rate curves related to Δp at constant reference signal values

spool type EL10

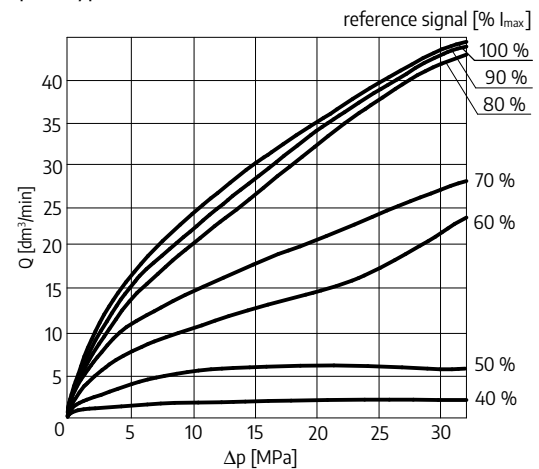

spool type EQ10

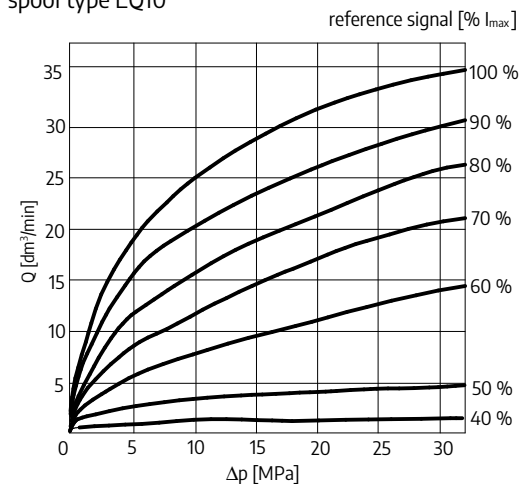

PERFORMANCE CURVES

measured at viscosity $\nu = 41 \text{ mm}^2/\text{s}$ and temperature $t = 50 \text{ }^\circ\text{C}$

flow rate curves related to the reference signal I
at constant Δp values

spool type WQ32

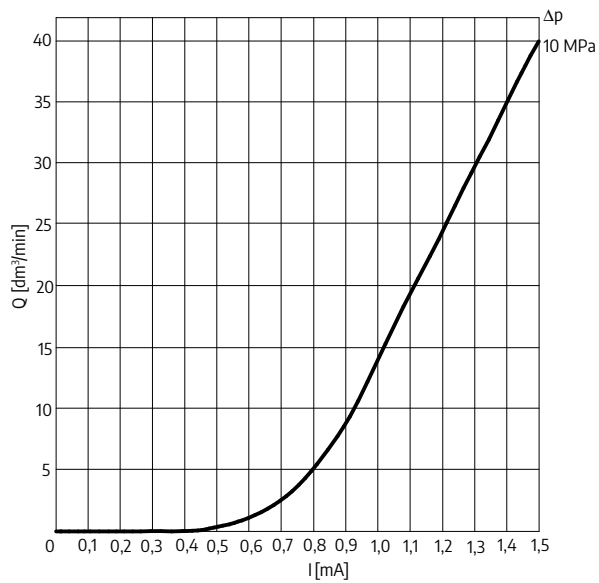
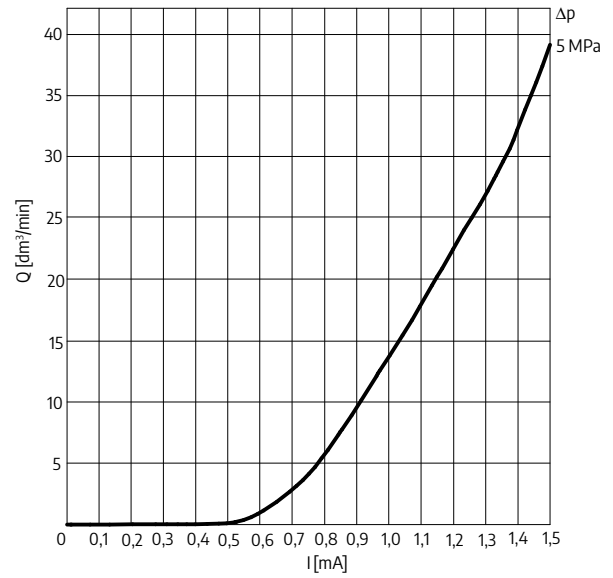
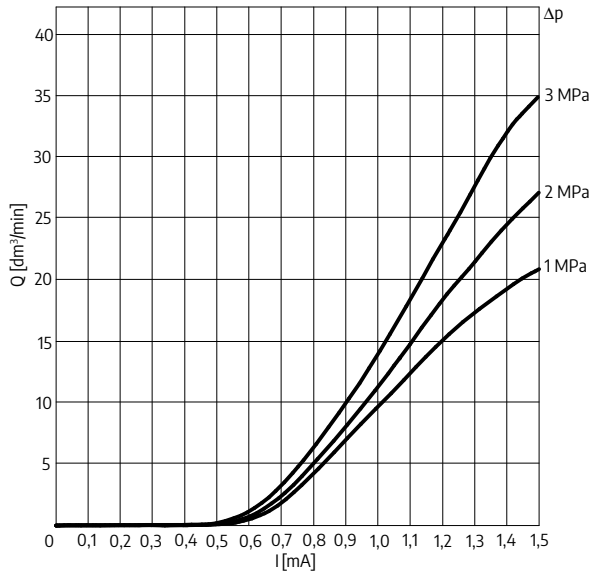

OVERALL AND CONNECTION DIMENSIONS

3-position versions USAB6.../...

2-position versions USAB6.../...A...; USAB6.../...B...

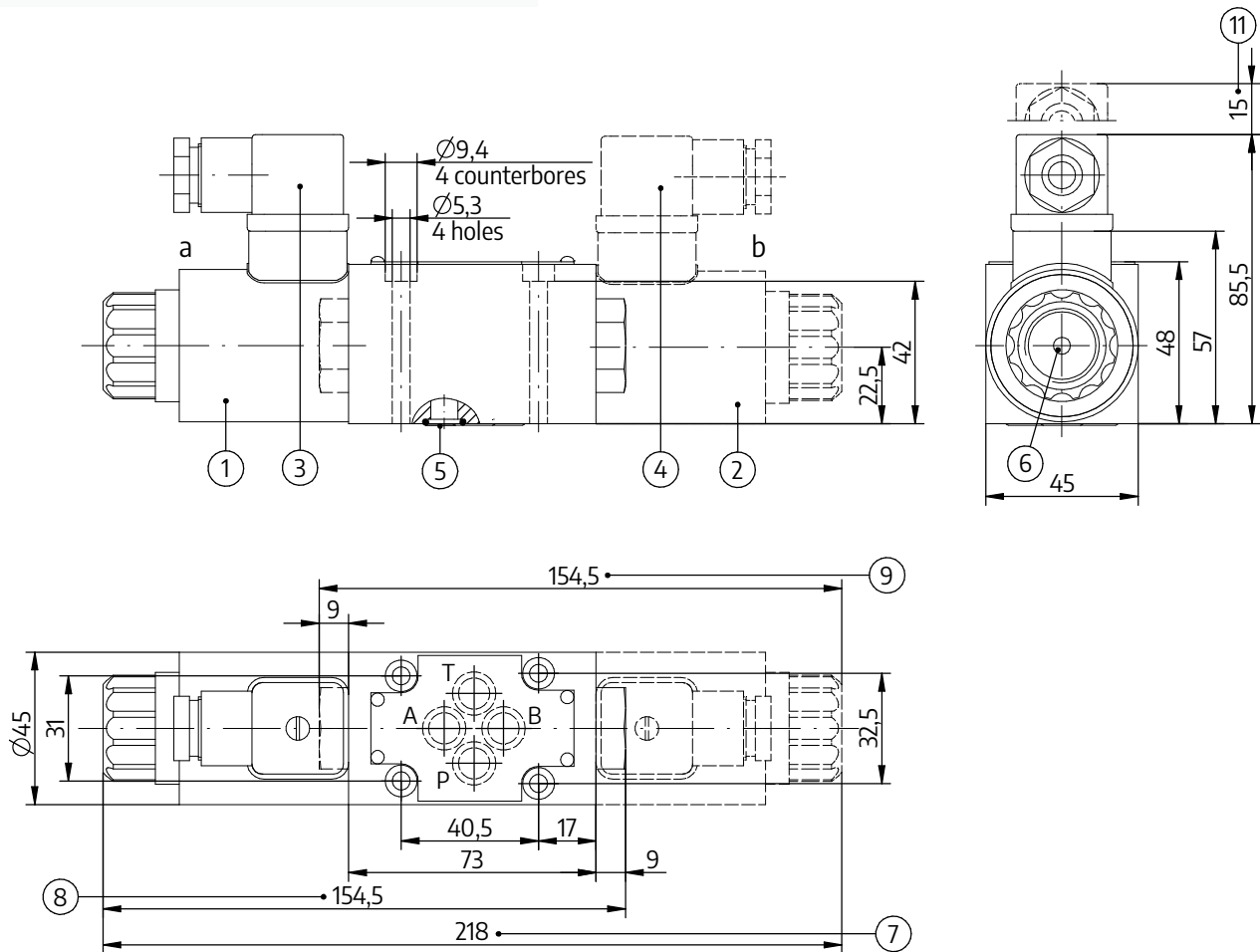

1. Solenoid at the **a** side
2. Solenoid at the **b** side
3. Plug-in connector at the **a** side – type ISO 4400 (DIN 43650 – A)
4. Plug-in connector at the **b** side – type ISO 4400 (DIN 43650 – A)
5. Sealing ring o-ring 9,2 x 1,8 - pcs 4/set (P, T, A, B)
6. Manual override
7. Overall dimension of 3-position version USAB6.../... with 2 solenoids at the **a** and the **b** side – spool symbols: E, E1, E2, E3, M, W, W1, W2, W3, V on page 1
8. Overall dimension of 2-position version USAB6.../...A... with 1 solenoid at the **a** side – spool symbols: EA, MA, WA on page 1
9. Overall dimension of 2-position version USAB6.../...B... with 1 solenoid at the **b** side – spool symbols: EB, MB, WB on page 1
10. Porting pattern – configuration of connection holes compliant with ISO 4401 standard; designation ISO 4401-03-02-0-94 (CETOP03); fixing screws M5 x 50 – 10.9 to PN – EN ISO 4762 – pcs 4/set delivered on separate order; tightening torque $M_d = 9 \text{ Nm}$
11. Space for disassembly of plug-in connectors – items 3, 4
12. Subplate surface required

HOW TO ORDER

USAB **6** – / – **N** **Z4**

1 2 3 4 5 6 7 8 9 10

1 nominal size

NS 6 =

6

4 flow changes

linear =

L

progressive =

Q

8 electrical connection

plug-in connector type ISO 4401 (DIN 43650-A) =

Z4

2 series number

(42 - 49) - connection and installation

dimensions unchanged =

4X

series 42 =

42

5 nominal flow rate at $\Delta p = 1$ MPa

10 dm³/min =

10

20 dm³/min =

20

32 dm³/min =

32

9 sealing

NBR (for fluids on mineral oil base) =

Ø

FKM (for fluids on phosphate ester base) =

V

for low temperatures =

NL

3 spool symbol

(spool diagrams according to page 1)

3-position = E, E1, E2, E3, W, W1, W2, W3, V

2-position = MA, WA, EB, MB, WB

6 solenoid coil

coil for max current $I_{max} = 1,5$ A =

12

coil for max current $I_{max} = 0,8$ A =

24

7 manual override

solenoids with manual override =

N

10 further requirements = *

(to be agreed with the manufacturer)

the mark „Ø” means the option with no designation

the symbols **in bold** are the preferred versions available

in short delivery time

SUBPLATES AND FIXING SCREWS

Subplates must be ordered according to Data Sheet WK 496 480.

Subplate symbols:

G341/01 – threaded connections G1/4

G342/01 – threaded connections **G3/8**

G502/01 – threaded connections G1/2

Subplate and fixing screws M5 × 50 – 10.9 according to

PN – EN ISO 4762 – pcs 4/set must be ordered separately.

Tightening torque $M_d = 9$ Nm.

NOTE:

The subplate symbol **in bold** is the preferred version available in short delivery time.

CONTACT

PONAR Wadowice S.A.
ul. Wojska Polskiego 29
34-100 Wadowice

phone +48 33 488 21 00
www.ponar-wadowice.pl